

CHANGING TABLE (Standard model dimensions)

A	B	C
Req'd. space to allow free travel up/down*	Width	Base height approx.
2100	800	Min.460 Max.860

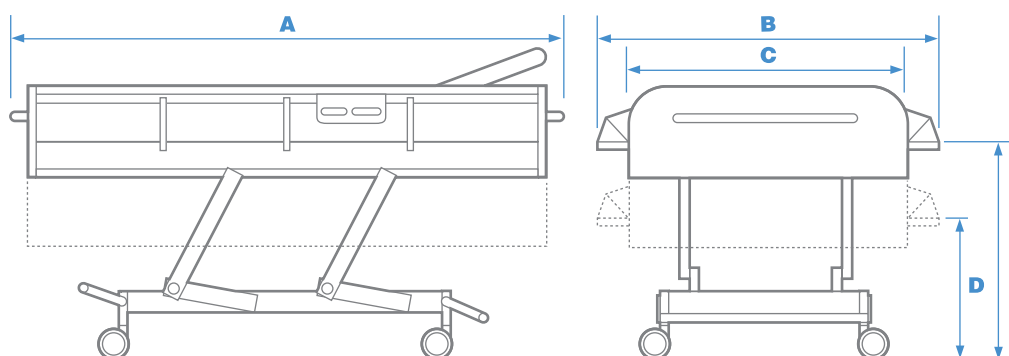

SHOWER CHANGER

Size	A	B	C	D	Internal width sides up	Internal length
	Req'd. space to allow free travel up/down*	Exterior width sides down	Exterior width sides up	Base height approx.		
Medium	2090	880	780	Min. 460	580	1680
Large	2350	940	840	Max. 860	640	1950

All dimension expressed in millimetres

*Standard frame travel clearance required – for confined areas a vertical rise frame is available

Maximum Load : 130kg/21st

Kingkraft Customer Care

The following services are offered to make the process of choosing your Kingkraft product as straight forward as possible. Kingkraft Care continues following delivery to ensure the products continue to provide the maximum benefit.

- Product demonstration and assessments
- Bathroom layout design and drawing
- Technical support both prior to order and following delivery
- Product commissioning
- 12 month product warranty (extended warranties available)
- On-going product servicing and preventative maintenance schemes

For full details of these services please contact our customer service department or refer to our product information folder.



Kingkraft Limited, 26D Orgreave Crescent, Dore House Industrial Estate, Sheffield S13 9NQ
 Telephone: 0114 269 0697 Fax: 0114 269 5145 Email: info@kingkraft.co.uk Web: www.kingkraft.co.uk

Due to the process of continuous development we reserve the right to alter specification without notice.